

FINISH	RAL 7035
IP PROTECTION RATING	IP 55
CABLE ENTRY	TOP
PANEL DEPTH	400

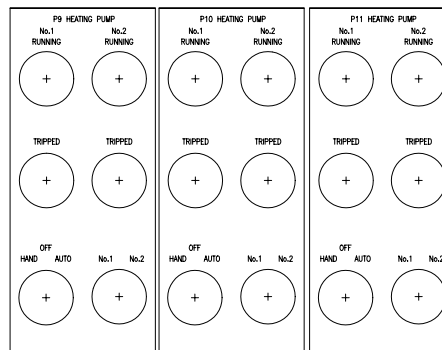
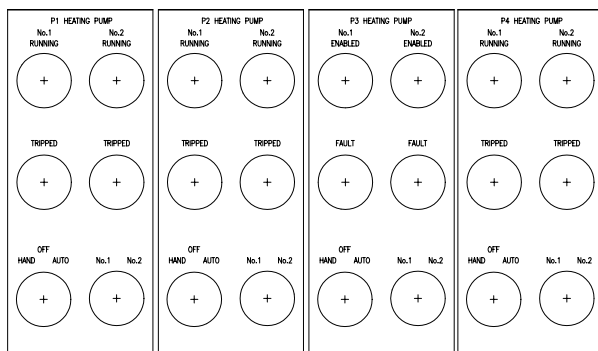
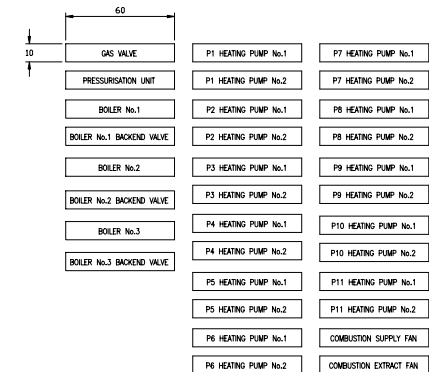
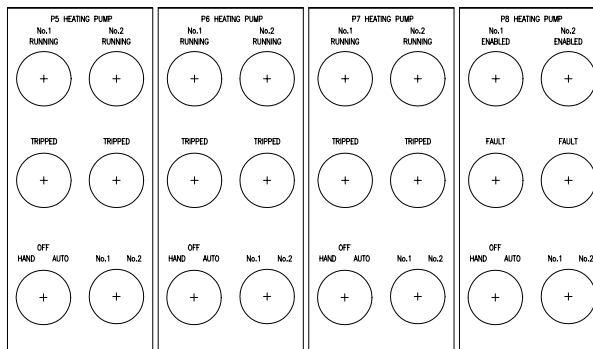
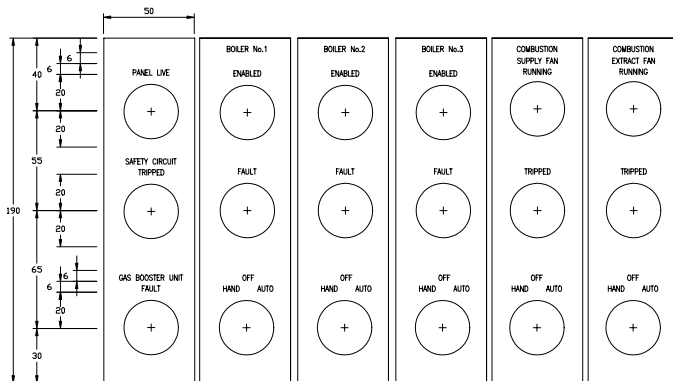

LEFT DOOR

RIGHT DOOR

SELF ADHESIVE

THICKNESS	3mm TRAFFOLYTE
COLOUR	WHITE/BLACK/WHITE TRAFFOLYTE
LETTERS	3mm LETTERS

ref : C5578\_A02 MINI

ref : C5578\_A02

THICKNESS	3mm TRAFFOLYTE
COLOUR	WHITE/BLACK/WHITE TRAFFOLYTE
LETTERS	3mm LETTERS
# 23 HOLES UNLESS OTHERWISE STATED	

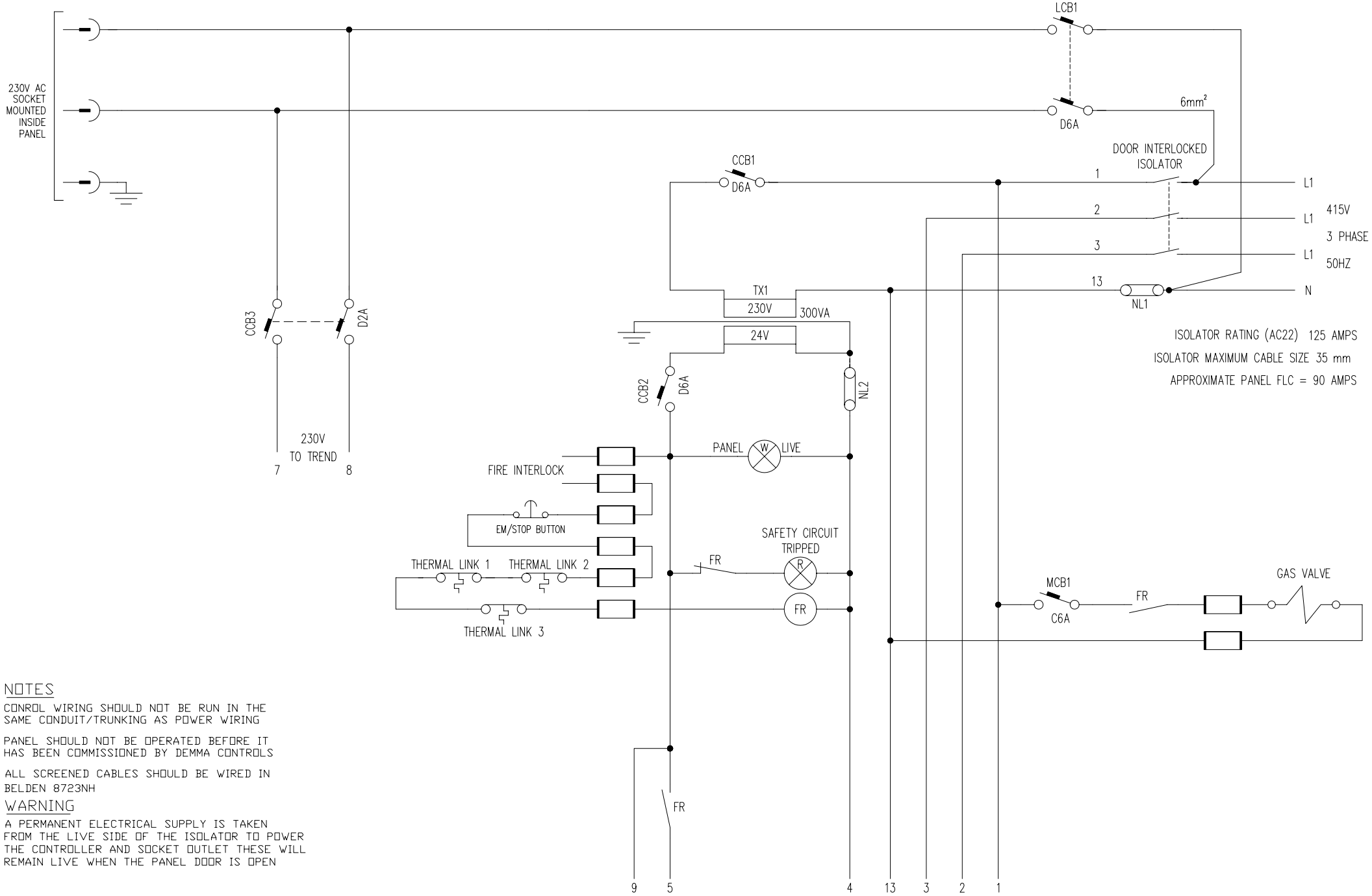

**NOTES**

- CONTROL WIRING SHOULD NOT BE RUN IN THE SAME CONDUIT/TRUNKING AS POWER WIRING
- PANEL SHOULD NOT BE OPERATED BEFORE IT HAS BEEN COMMISSIONED BY DEMMA CONTROLS
- ALL SCREENED CABLES SHOULD BE WIRED IN BELDEN 8723NH

**WARNING**

A PERMANENT ELECTRICAL SUPPLY IS TAKEN FROM THE LIVE SIDE OF THE ISOLATOR TO POWER THE CONTROLLER AND SOCKET OUTLET THESE WILL REMAIN LIVE WHEN THE PANEL DOOR IS OPEN

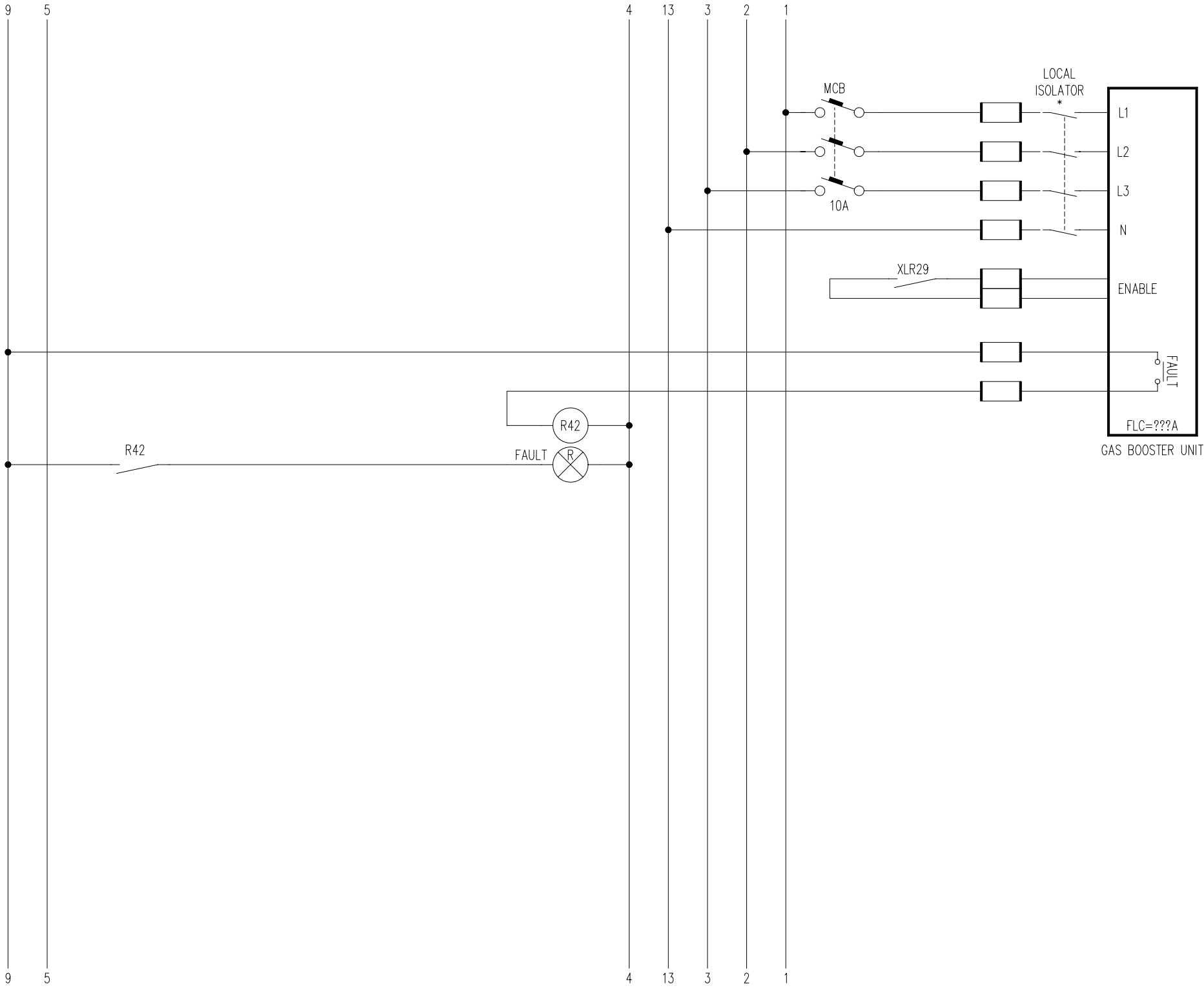

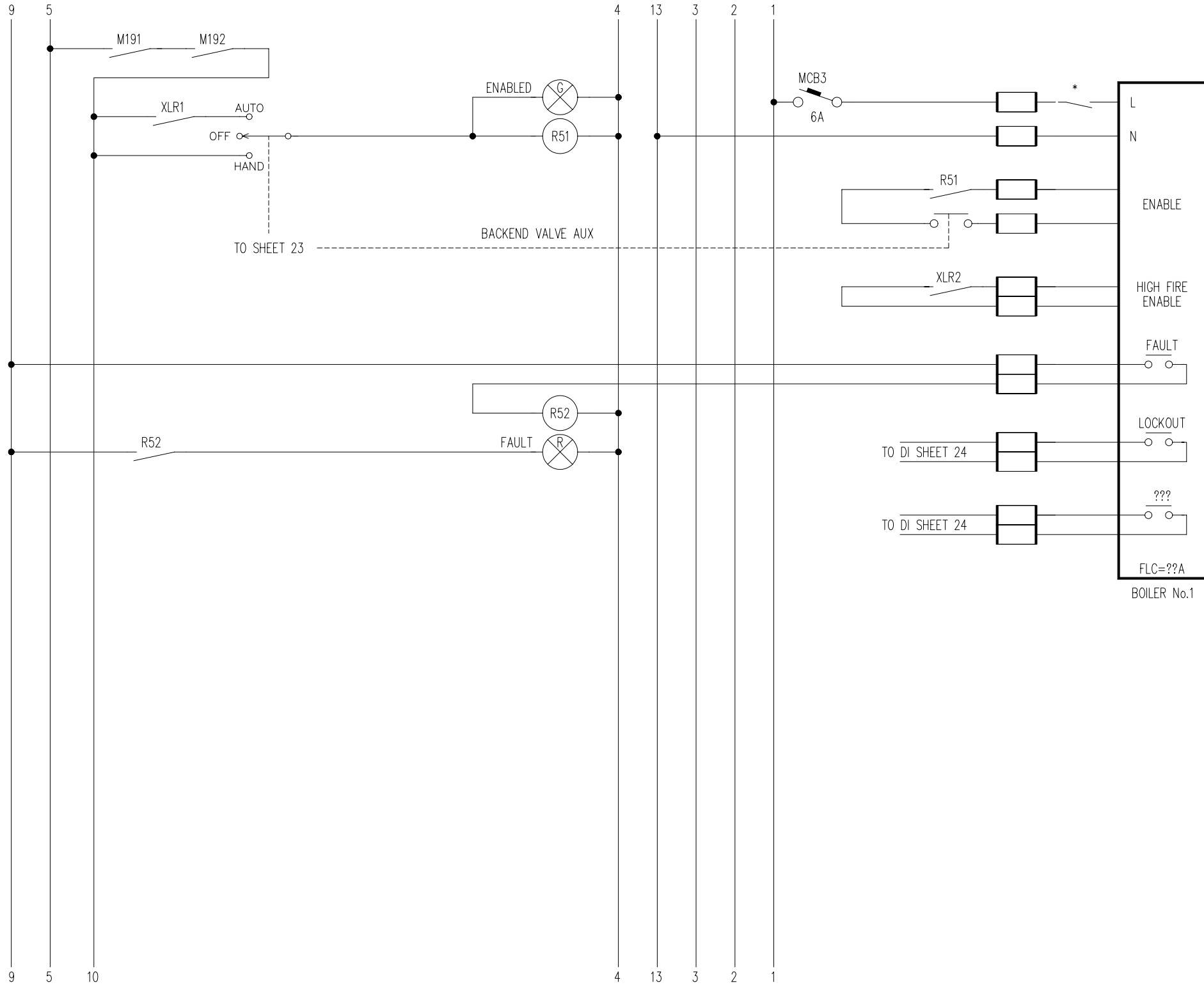

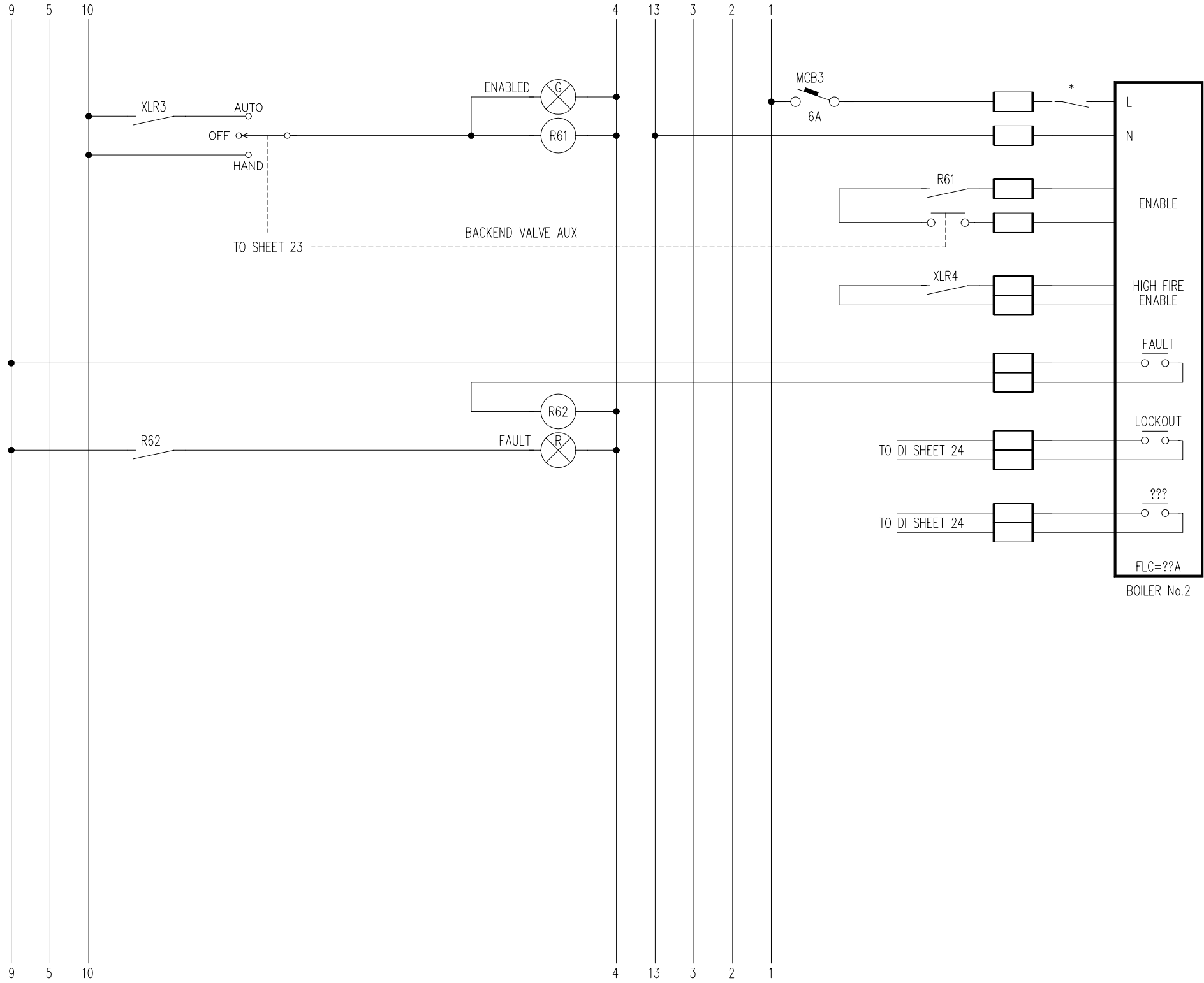

ALL SENSORS MUST BE INSTALLED AWAY FROM EXTRANEIOUS HEAT SOURCES NOT JUST SPACE SENSORS

Outside air temperature

AHU supply air temperature

Boiler No.1 flow temperature

Boiler No.1 Return temperature

Boiler No.2 flow temperature

Boiler No.2 Return temperature

Boiler No.3 flow temperature

Boiler No.3 Return temperature

VT flow temperature

VT Return temperature

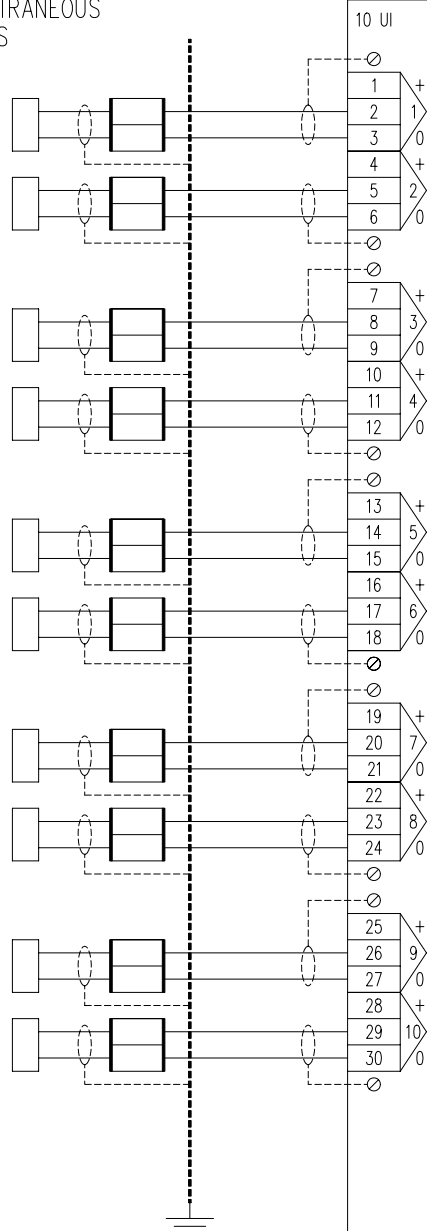

IQ3/96  
OS 1

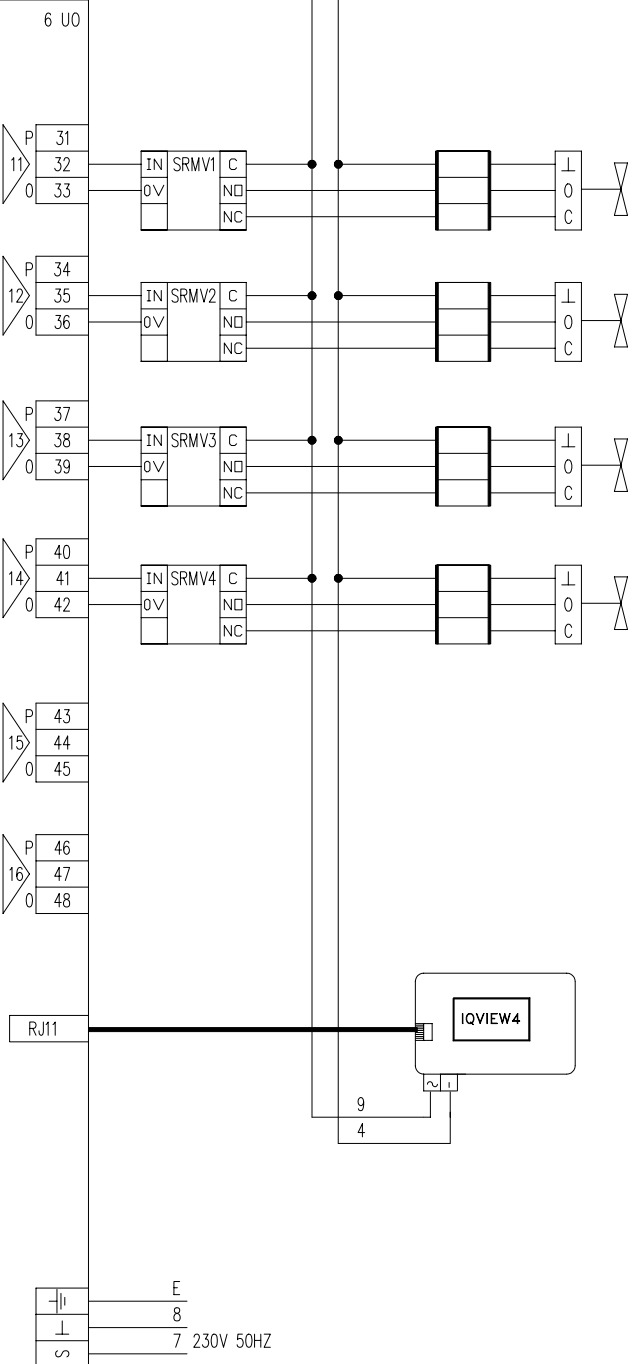

VT Valve 1

VT Valve 2

DHW Valve

AHU Valve

IOVIEW4

RJ11

E  
8  
7 230V 50HZ

